

# SERPAC 152

Electronics Enclosures

NOTES:  
1. WHEN MACHINE OR I PLATES MODIFICATIONS ARE REQUIRED, USE THE CENTER OF THE BOX TO DIMENSION.

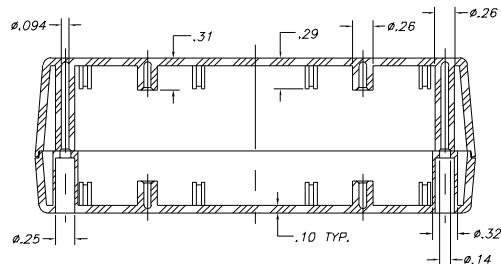
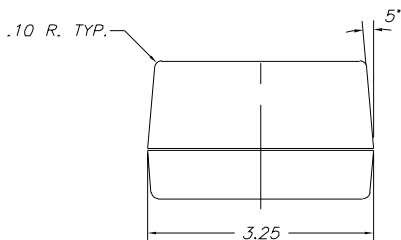
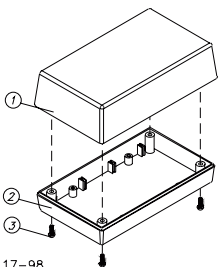
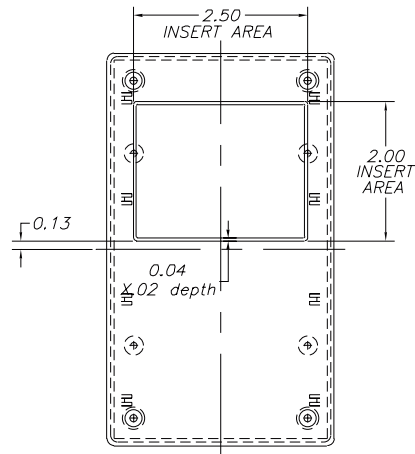
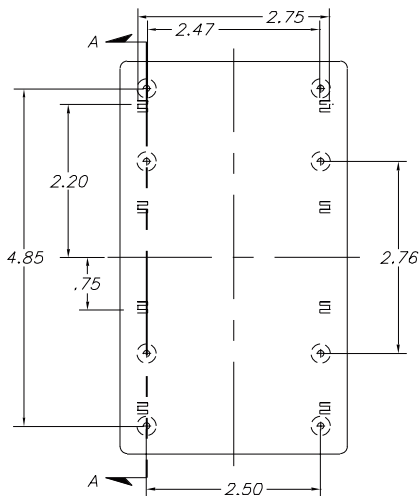
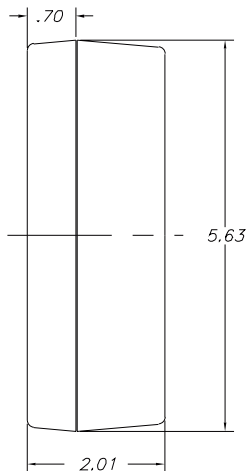

8-17-98.

ALL DIMENSIONS ± .010

ITEM	PART NO.	DESCRIPTION	ACCESSORIES	
1	52	PLASTIC TOP	PART NO.	DESCRIPTION
2	15	PLASTIC BOTTOM	50	FEET
3	6005	SCREWS (4)	350	PROTOTYPE GRID BOARD (HORIZ.)
			450	PROTOTYPE CLAD BOARD (HORIZ.)
			332	PROTOTYPE GRID BOARD (VERT.)
			432	PROTOTYPE CLAD BOARD (VERT.)
			PS-15	PERIMETER SEAL
			PC	POCKET CLIP

619 Commercial Ave. Covina, CA 91723

(626) 331-0517 Fax (626) 331-8584 <http://www.serpac.com>